



INSTALLATION MANUAL

Parts list

1	Bull bar
2	Mounting bracket, universal
8	Hex bolt, M8 - 1.25 x 25mm
8	Hex nut, M8 x 1.25
8	Flat washer, M8
1*	LED wiring harness*

* Wiring harness only included with LED equipped models

Tools Required

Ratchet	Socket, 13mm
Torque wrench	Socket, 18mm

Torque Specifications

	Torque Specifications	
METRIC	M6 bolt	3 ft.-lbs.
	M8 bolt	7 ft.-lbs.
	M10 bolt	16 ft.-lbs.
	M12 bolt	28 ft.-lbs.
SAE	1/4" bolt	3 ft.-lbs.
	5/16" bolt	7 ft.-lbs.
	3/8" bolt	16 ft.-lbs.
	7/16" bolt	20 ft.-lbs.
	1/2" bolt	28 ft.-lbs.

Level of Difficulty

Easy



Scan for helpful install tips

Product Image



2153003

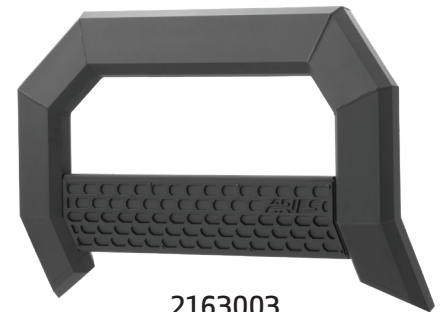

2163003



2153103



2163103

Notes and Maintenance

Before you begin installation, read all instructions thoroughly.

Proper tools will improve the quality of installation and reduce the time required.

For chrome powder coat, polish may be used to clear small scratches and scuffs on the finish. Mild soap may be used also to clean the product.

For black finishes, mild soap may be used to clean the product.

Refer to the table to the left when securing hardware during the installation process to help prevent damage to the product or vehicle.

Step 1

Locate the two mounting points on the front of the vehicle.



Step 2

Remove the driver side plastic cover above the tow hook.

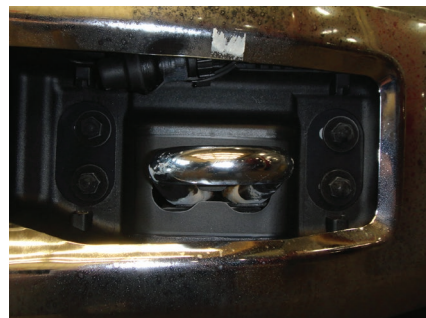

Step 3

Remove the two outer factory bolts and double nut plate.

Repeat steps 2 and 3 on the passenger side.



Step 4

Lay the bull bar on a flat surface in order to attach the mounting brackets.

Insert two M8 hex bolts into each of the rail slots.

Place the driver-side bracket over the bolts and secure the bracket to the bull bar using an M8 flat washer and nylock nut.

Snug the hardware, but do not fully tighten. Repeat this step for the passenger-side bracket.

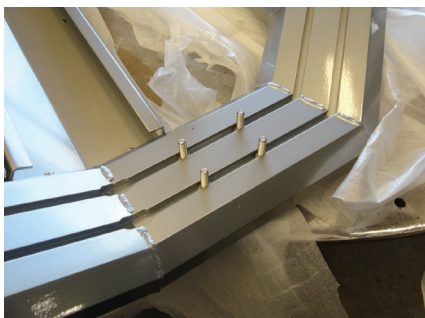

Step 5

With help, lift the bull bar into place and align the mounting tabs on the bull bar brackets with the mounting points on the vehicle.

Secure the brackets to the vehicle using the previously removed factory hardware.

Snug hardware, but do not fully tighten.



Step 6

Level and adjust the bull bar into the desired position and tighten all hardware.

Tighten all hardware to the recommended torque specifications listed in the table on the first page.

If your bull bar is not equipped with lights skip to step 9.

If your bull bar is equipped with lights complete steps 7 and 8.

Note: If the LED lights are being used with a 24V system, the 12V relay will need to be replaced with a 24V unit.



Step 7 - For Models with LED Lights Included

Disconnect the supplied switch from the wire harness and install in desired location.

With the switch installed, route the wire harness to the LED lights and the switch.

Reconnect the blue, red and black spade connectors to the switch as shown.

Note: The black wire connects to the gold switch terminal.

Plug the male connector on the wire harness into the female connector attached to the LED lights.

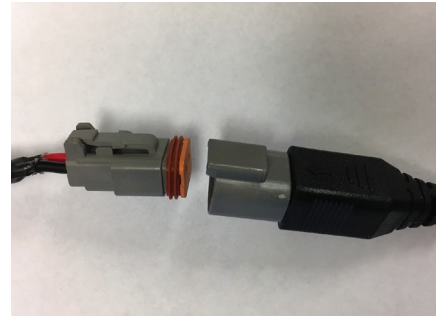
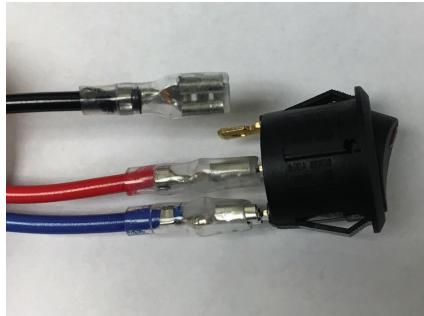

Step 8 - For Models with LED Lights Included

Connect the red fused wire with the ring terminal to the positive battery post.

Connect the black wire ring terminal to the negative battery post or other suitable vehicle grounding point.

Mount the supplied relay to the vehicle and secure all wires with zip ties away from moving parts to avoid damage.

Test the lights to ensure proper function.

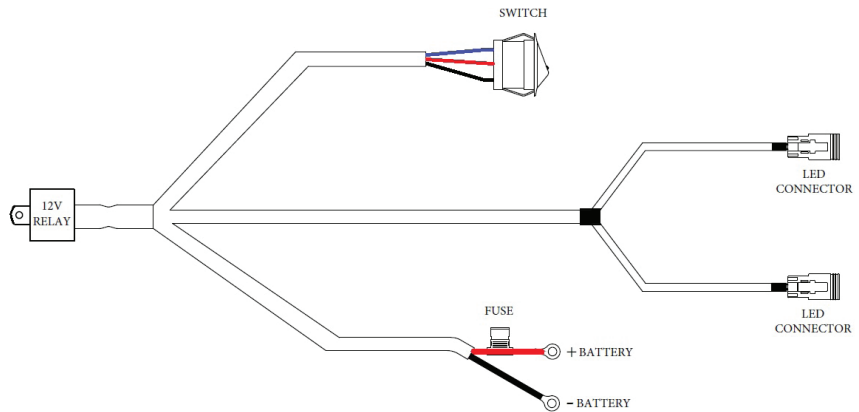

Step 9

Congratulations on the installation of your new ARIES AdvantEDGE™ bull bar.

With the bull bar installed, periodic inspections should be performed to ensure all mounting hardware remains tight.

To protect your investment, see the 'Notes and Maintenance' section on the first page of this instruction manual.

