

INSTALLATION MANUAL

ANGULAR BRUSH GUARD

Level of Difficulty

Easy

This is the third of three manuals required to complete this installation. The first manual is included with your center section. The second manual is included with your bumper corners.

Parts List

1	Angular brush guard
6	Buttonhead cap screw, M6
12	Flat washer, M6
6	Nylock nut, M6
4	Hex bolt, M10
8	Flat washer, M10
4	Lock washer, M10
4	Nut, M10
1	Cover plate

Tools Required

Ratchet	Phillips screwdriver
Socket extension	Flathead screwdriver
Socket set	Allen wrench set
Level	Box wrench set

Torque Specifications

M6 bolt	7 ft-lbs.
M8 bolt	16 ft-lbs.
M10 bolt	33 ft-lbs.
M12 bolt	58 ft-lbs.

Use above torque setting unless otherwise noted

Product Photo

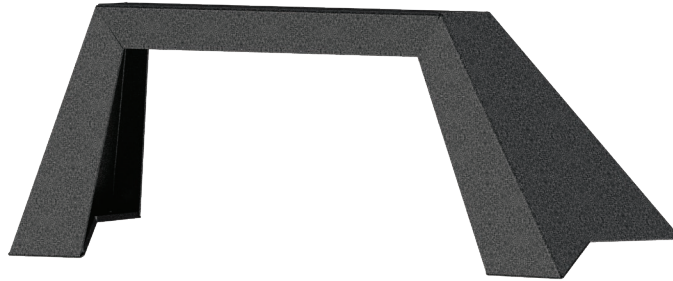

Applicable to the Following Part Numbers

2081101	2081100
---------	---------

Notes and Maintenance

Before you begin installation, read all instructions thoroughly.

Proper tools will improve the quality of installation and reduce the time required.

Mild automotive detergent may be used to clean the product. Do not use dish detergent, abrasive cleaners, abrasive pads, wire brushes or other similar products that may damage the finish.

Refer to the table to the left when securing hardware during the installation process to help prevent damage to the product or vehicle.

Product Registration

CURT Group stands behind our products with industry leading warranties. You can help us continue to improve our product line and help us understand your needs by registering your purchase by visiting:

warranty.curtgroup.com/surveys

At CURT Group, customer is king. We value your feedback and we use that information to make improvements on our products. Please, take a minute and let us know how we are doing.

Step 1

Place the cover plate on top of the brush guard. Insert an M6 button head cap screw with flat washer and secure with a nylock nut.

Repeat for all six attachment points.

Adjust if necessary and fully tighten all hardware with an Allen wrench.

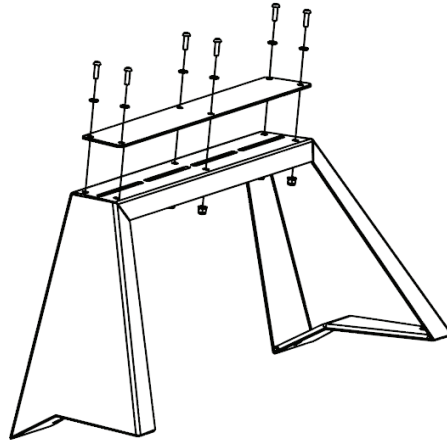

Step 2

Place the center section onto a flat work surface. Lift the brush guard into place and insert an M10 hex bolt with locking and flat washer. Secure the bolt with a second flat washer and a hex nut.

Repeat this for all four attachment points.

Adjust if necessary and fully tighten all the hardware with a 16mm socket and wrench.

Note: To finish the installation, continue to step 7 of the manual included with your center section.

