

# **INSTALLATION INSTRUCTIONS**

**2064/2064-2 GRILLE GUARD**

**2011-12 TOYOTA HIGHLANDER (EXCLUDES HYBRID)**

**PARTS LIST:**

Qty	Description	Qty	Description
1	Grille Guard	2	12mm x 37mm OD x 3mm Large Flat Washer
1	Driver/Left Mounting Bracket	18	12mm x 32mm OD x 3mm STD Flat Washers
1	Passenger/Right Mounting Bracket	10	12mm Nylon Lock Nuts
1	Driver/Left Lower Support Bracket	2	10-1.25mm x 35mm <b>Special Fine Thread</b> Hex Bolts
1	Passenger/Right Lower Support Bracket	2	10-1.5mm x 35mm STD Thread Hex Bolt
1	Driver/Left Top Bracket	2	10mm x 27mm OD x 3mm Large Flat Washers
1	Passenger/Right Top Bracket	2	10mm x 20mm OD x 2mm Small Flat Washer
1	50mm x 400mm x 1mm Adhesive Backed Foam Tape	4	10mm Lock Washers
2	12-1.75mm x 90mm Bolt Plates	2	8-1.25mm x 30mm Button Head Bolts
2	10mm Nut Plates	8	8mm x 24mm OD x 2mm Flat Washers
8	12-1.75mm x 30mm Hex Bolts	2	8mm Nylon Lock Nuts

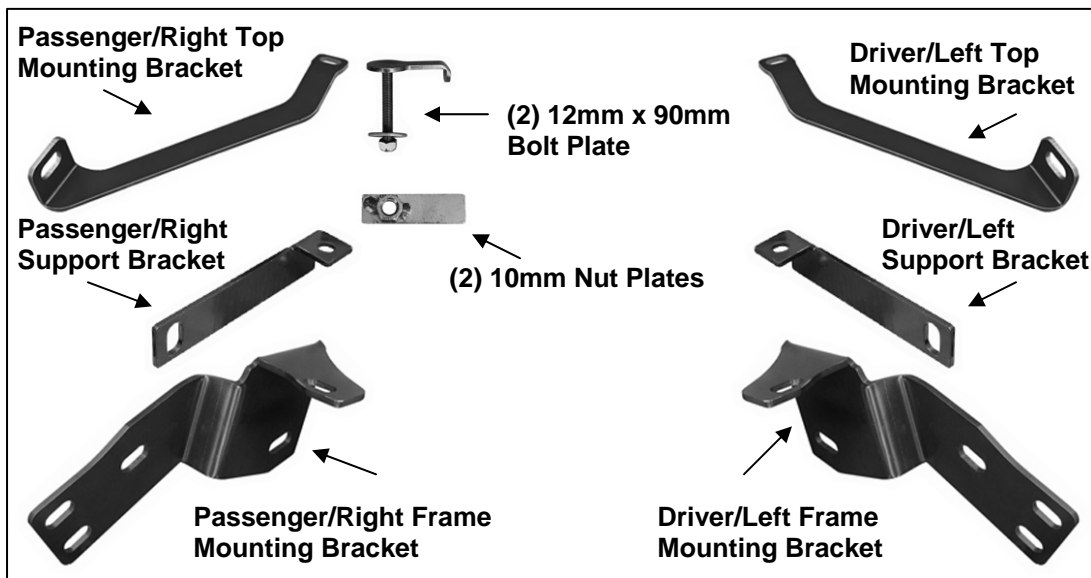

**PROCEDURE:**

1. REMOVE CONTENTS FROM BOX. VERIFY ALL PARTS ARE PRESENT. READ INSTRUCTIONS CAREFULLY BEFORE STARTING INSTALLATION. CUTTING IS REQUIRED. ASSISTANCE IS RECOMMENDED.
2. Start installation from under the front of the vehicle. Remove the plastic splash guard, (Figure 1).  
**NOTE:** Pay close attention to the location of all factory hardware for reinstallation.
3. Locate the driver side factory vibration dampener on top of the cross member, (Figure 4). The vibration dampener covers a mounting location for the driver side Support Bracket. Temporarily remove the dampener from the top of crossmember. **IMPORTANT:** Pay close attention to how the dampener is mounted to the crossmember as it will be reinstalled.
4. Remove the plastic plugs covering the holes through the crossmember on the driver and passenger side, (Figure 2). Select the appropriate installation:
  - a. **Driver Side Support Bracket Installation:** Insert (1) 12mm x 90mm Bolt Plate down through the crossmember from the top, (Figures 3A & 3B). Re-install the vibration dampener over the Bolt Plate using the factory hardware. **NOTE:** Use the included 8mm Flat Washers on the factory hex bolts for spacers between the dampener and the crossmember as required for proper Bolt Plate clearance, (Figure 4). Rotate the lock tab on the Bolt Plate for proper fit between the crossmember and dampener. Select the driver side Support Bracket. Attach the end with the bent tab to the Bolt Plate with the included (1) 12mm x 32mm STD Flat Washer and (1) 12mm Nylon Lock Nut, (Figure 5). Do not tighten hardware at this time.

- b. **Passenger Side Support Bracket Installation-V6 and 4cyl. W-O A/C:** Repeat **Step 4a** for passenger side Support Bracket installation.
  - c. **Passenger Side Support Bracket Installation-4cyl W-A/C:** Due to the close proximity of the AC compressor, (if equipped), the 12mm x 90mm Bolt Plate must be installed from the bottom up, through the passenger side Support Bracket first and up through the crossmember, (**Figure 6A**). Select the passenger side Support Bracket. Insert (1) Bolt Plate up through the Support Bracket and the holes in the crossmember. Secure the Support Bracket with (1) 12mm x 37mm Large Flat Washer and (1) 12mm Nylon Lock Nut on top of the crossmember below the AC Compressor. **IMPORTANT:** Leave as much room as possible between the Bolt Plate and the AC compressor. If additional clearance is required, slide (1) 12mm x 37mm Washer over the Bolt Plate first, between the head of the Bolt Plate and the Support Bracket to act as a spacer, (**Figure 6B**). Snug but do not tighten hardware at this time.
5. Select the driver side Frame Mounting Bracket. Locate the two factory bolts on the crossmember brace leading towards the bumper. Remove the factory hex bolt towards the outside of the vehicle, (**Figure 7**). Position the driver side Mounting Bracket up to the bottom of the crossmember brace. Bolt the Mounting Bracket to the bottom of the brace using the included (1) 10-1.25mm x 35mm **Special Fine Thread** Hex Bolt, (1) 10mm Lock Washer and (1) 10mm x 27mm Large Flat washer, (**Figure 8**). Do not tighten hardware at this time.
  6. Attach the flat end of the Support Bracket to the outside of the Mounting Bracket using the included (1) 12mm x 30mm Hex Bolt, (2) 12mm STD Flat Washers and (1) 12mm Nylon Lock Nut, (**Figures 8 & 13**). Do not tighten hardware at this time.
  7. Repeat **Steps 5 & 6** for passenger side Frame Mounting Bracket installation.
  8. Once you have attached the driver and passenger Mounting Brackets and Support Brackets, hold the factory plastic splash guard up in its original mounting position and trace the location of the (2) Frame Mounting Brackets and the (2) Bolt Plates onto the splash guard. Use a sharp knife to cut out the traced area for the Mounting Brackets. **IMPORTANT:** To maintain strength in the splash guard, only remove necessary material to clear the Frame Mounting Brackets. **NOTE:** The Support Brackets will install over the plastic cover. Use a 1/2" drill bit or a sharp knife to open holes for the (2) Bolt Plates to go through the cover.
  9. Temporarily remove the Support Brackets. Re-install the trimmed splash guard onto the bottom of the vehicle but do not fully fasten-leave loose at this time to access the Bolt Plate hardware. Reinstall the Support Brackets but do not tighten hardware at this time.
  10. Open the hood and remove the plastic cover over the top of the radiator, (**Figure 9**). Locate the hole in the radiator cross support, (**Figure 9**).
  11. Select the driver side Top Bracket. Apply a section of Adhesive Backed Foam Tape to the Top Bracket to protect the plastic grille from contact with the Bracket, (**Figure 11**). With assistance, insert the Top Bracket through the opening in the top of the grille and line up the flat end with the mounting hole. Hold (1) 10mm Nut Plate up in position from under the radiator support, (**Figures 10A & 10B**). Line up the Nut Plate with the hole. Bolt the Top Bracket to the Nut Plate with (1) 10mm Hex Bolt, (1) 10mm Lock Washer and (1) 10mm x 20mm Small Flat Washer, (**Figure 12**). Leave loose at this time.
  12. Repeat **Steps 10 & 11** for passenger side Top Bracket installation, (**Figure 13**).
  13. With assistance, position the Grille Guard onto the outside of the Mounting Brackets. Attach the Grille Guard to the Frame Mounting Brackets with the included (6) 12mm x 30mm Hex Bolts, (12) 12mm x 32mm STD Flat Washers and (6) 12mm Nylon Lock Nuts, (**Figure 14**).
  14. Remove and discard the top hex bolt holding the headlight guard to the loop on the driver side of the Grille Guard, (**Figure 15**). Line up the driver side Top Bracket with the mounting hole in the upright. Bolt the Top Bracket to the upright with (1) 8mm x 30mm Button Head Bolt, (2) 8mm Flat Washers and (1) 8mm Nylon Lock Nut, (**Figure 16**). Do not tighten hardware at this time.
  15. Repeat **Step 14** for passenger side Top Bracket installation.
  16. Level and adjust the Grille Guard and tighten all hardware at this time. **IMPORTANT:** Tighten all hardware including the Support Bracket and Bolt Plate hardware.
  17. Re-attach plastic cover and lower splash guard to the vehicle using the factory hardware.
  18. Do periodic inspections to the installation to make sure that all hardware is secure and tight.

To protect your investment, wax this product after installing. Regular waxing is recommended to add a protective layer over the finish. Do not use any type of polish or wax that may contain abrasives that could damage the finish.

**For stainless steel:** Aluminum polish may be used to polish small scratches and scuffs on the finish. Mild soap may be used also to clean the Grille Guard.

**For gloss black finishes:** Mild soap may be used to clean the Grille Guard.

### Driver Side Installation Pictured

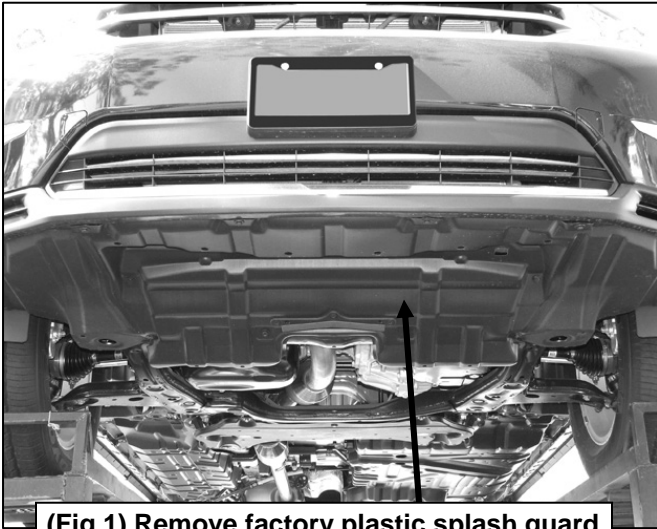

(Fig 1) Remove factory plastic splash guard

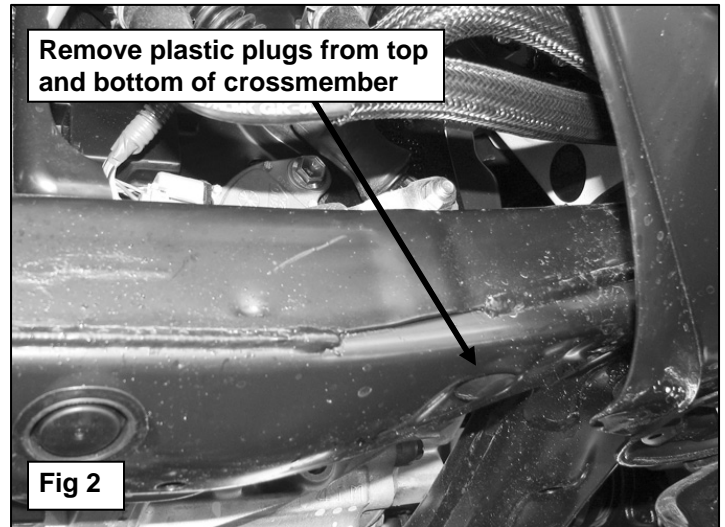

Fig 2

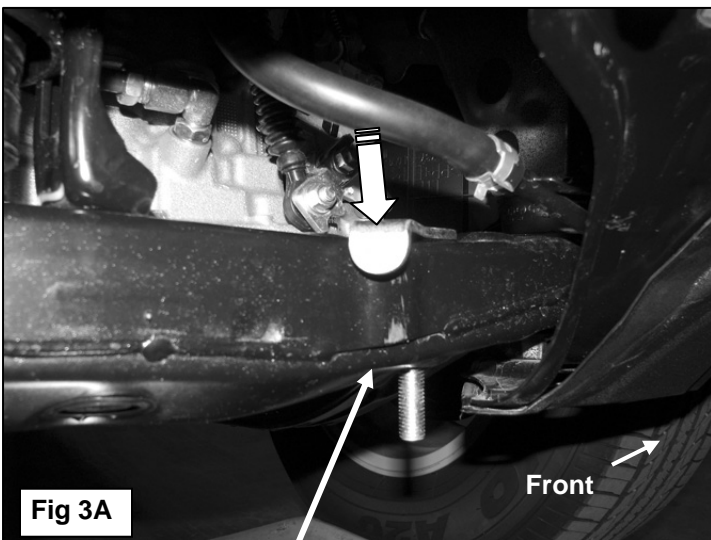

Fig 3A

Use supplied 8mm Flat Washers as spacers for vibration dampener

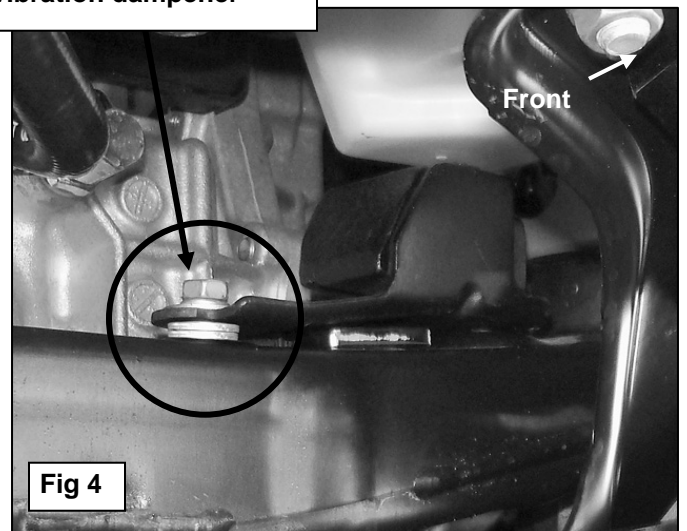

Fig 4



Fig 3B

12mm Bolt Plate  
12mm STD Flat Washer  
12mm Nylon Lock Nut



(Fig 5) Driver side pictured

Highlander with 4cyl and air conditioning:  
Insert Bolt Plate up through passenger  
side Support Bracket and crossmember.  
Use 12mm Large Flat Washer for more  
clearance if required

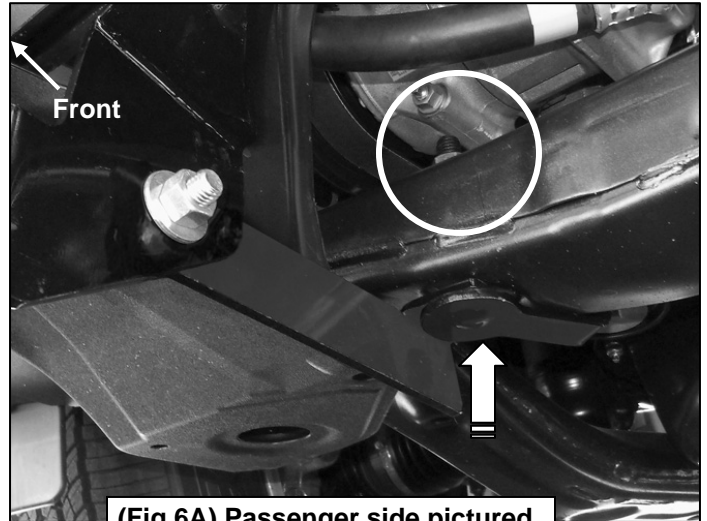

(Fig 6A) Passenger side pictured

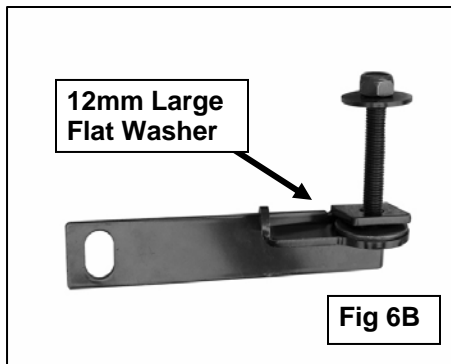

12mm Large  
Flat Washer

Fig 6B

10-1.25mm x 30mm FINE  
THREAD Hex Bolt  
10mm Lock Washer  
10mm Large Flat Washer

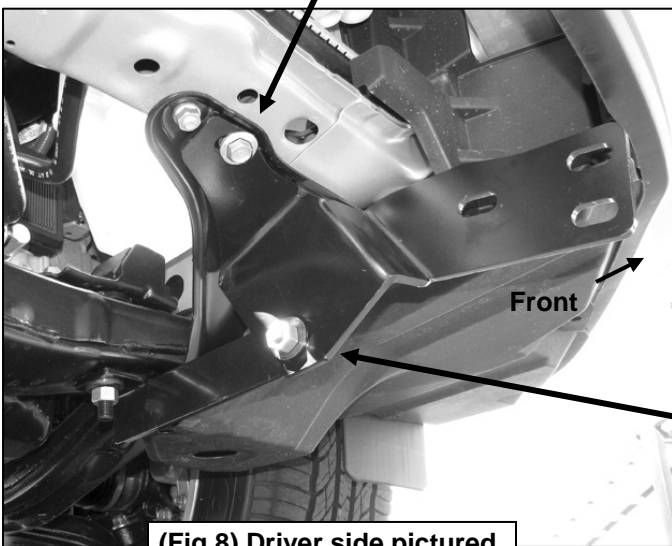

(Fig 8) Driver side pictured

Remove outer 10mm hex bolt

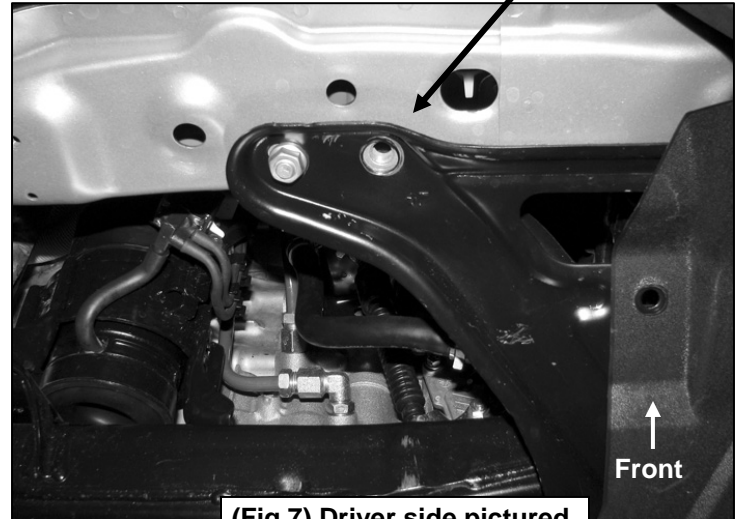

(Fig 7) Driver side pictured

12mm x 30mm Hex Bolt  
(2) 12mm STD Flat Washers  
12mm Nylon Lock Nut

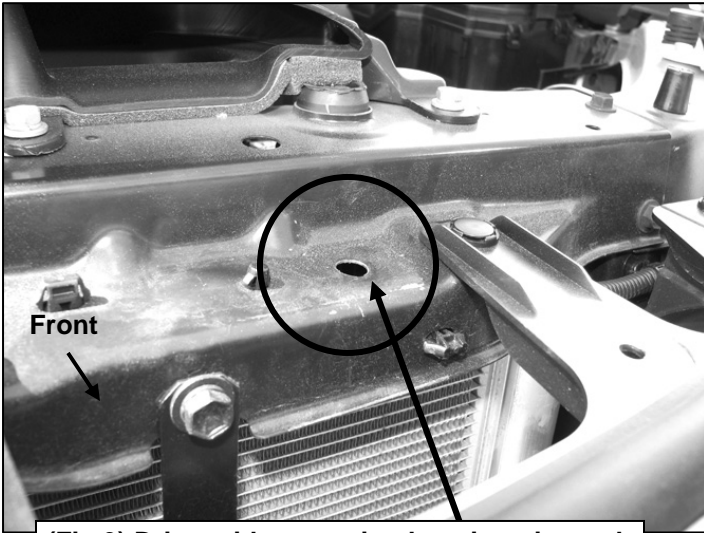

(Fig 9) Driver side mounting location pictured

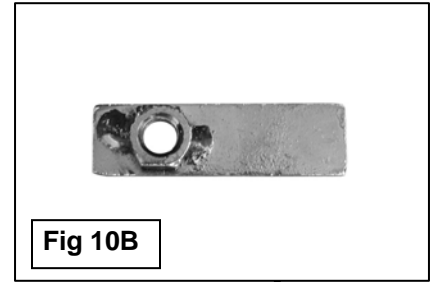

Fig 10B

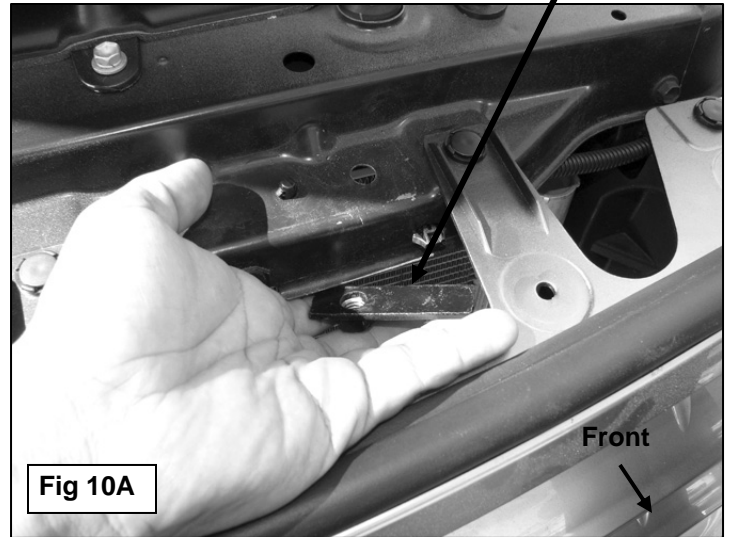
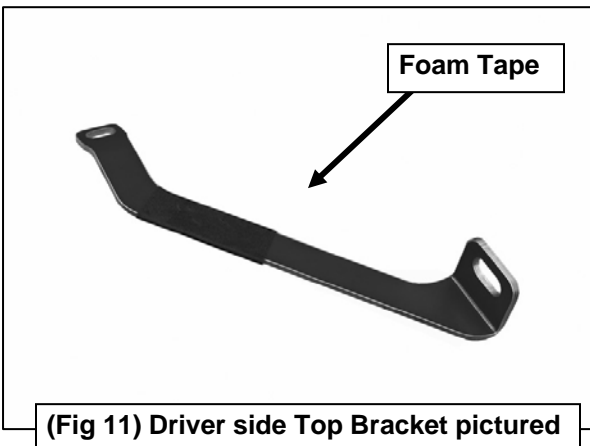
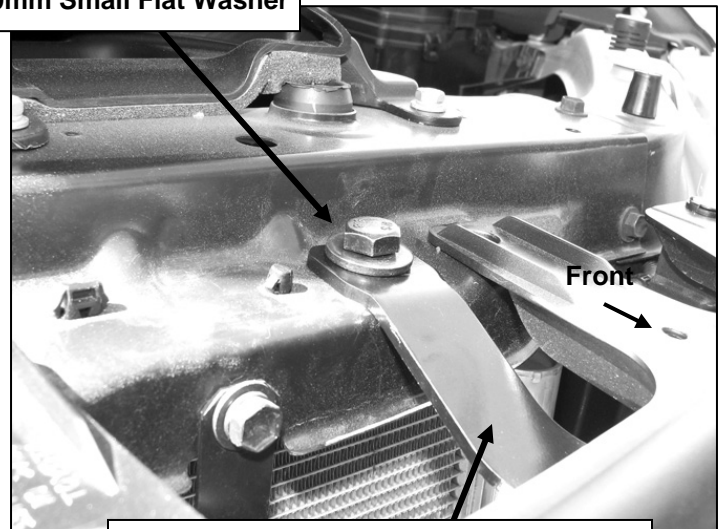

Fig 10A



(Fig 11) Driver side Top Bracket pictured

- 10mm Nut Plate
- 10mm x 30mm Hex Bolt
- 10mm Lock Washer
- 10mm Small Flat Washer



(Fig 12) Driver side Top Bracket pictured

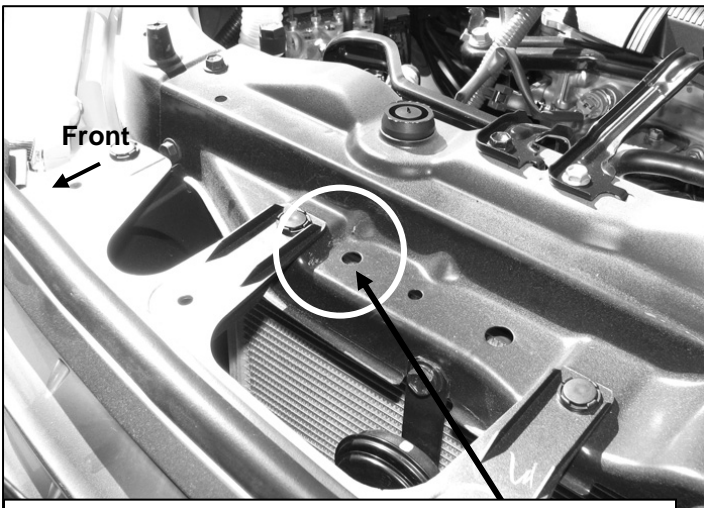

(Fig 13) Passenger side mounting location pictured

### Driver Side Installation Pictured



(Fig 14) Driver side pictured without splash guard for instruction purposes only

- (3) 12mm x 30mm Hex Bolts
- (6) 12mm STD Flat Washers
- (3) 12mm Nylon Lock Nuts

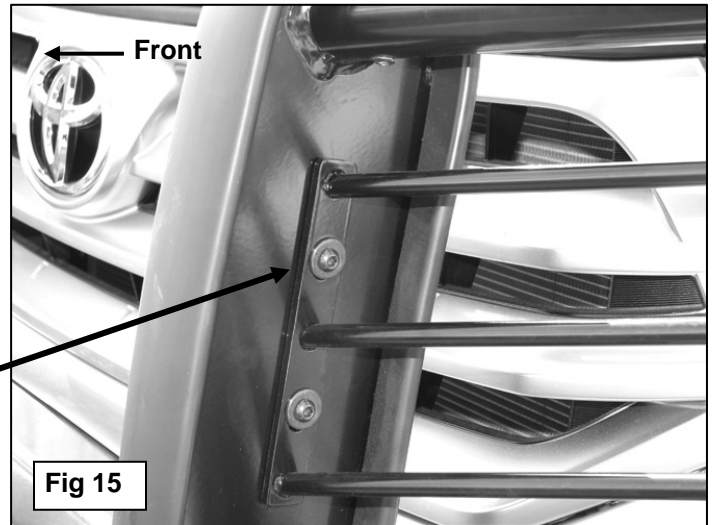
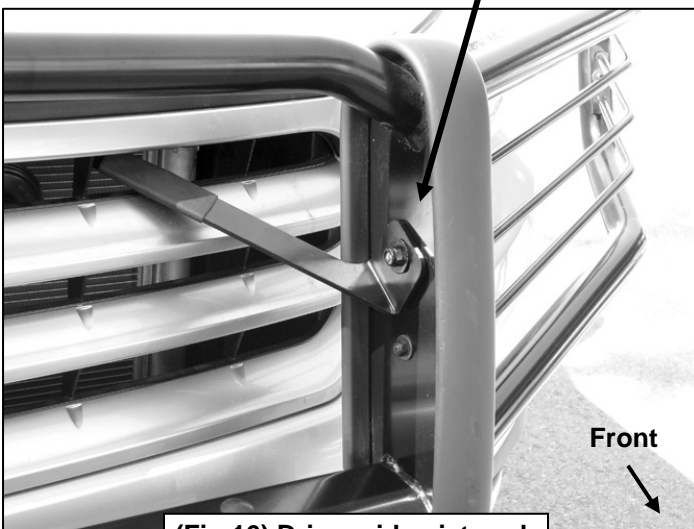

Fig 15

Remove 8mm Hex Bolt and attach Top Bracket to upright with:  
8mm x 30mm Button Head Bolt  
(2) 8mm Flat Washers  
8mm Nylon Lock Nut



(Fig 16) Driver side pictured



Complete Installation