

Parts List

2	LED work light, flush mount
1	Wiring harness
8	Socket head cap screw, M6 - 1.0 x 16mm
8	Flat washer, M6
8	Nylock nut, M6
2	Rubber spacer
1	5-amp fuse, pre-installed

Level of Difficulty

Easy



Scan for helpful install tips

Product Image



Step 1

Mount the LED lights in the desired location with a rubber spacer between the mounting surface and light.

Note: If these lights are being used with a 24V system, the relay will need to be replaced with a 24V unit.

Disconnect the supplied switch from the wiring harness and install in the desired location.

Wiring Diagram

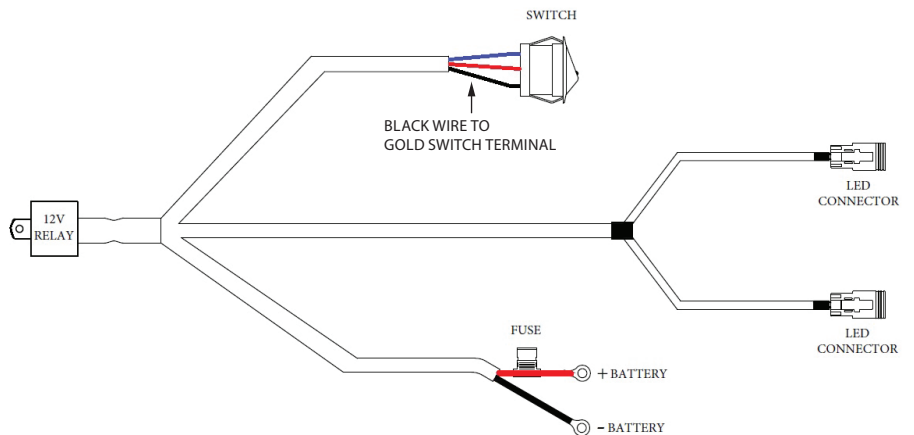

Step 2

Once the LED lights and switch are installed, route the wiring harness to each light. Insert the male plug on the wiring harness into the female socket on each LED light. Reconnect the blue, red and black spade connectors to the switch (see the wiring diagram).

Step 3

Connect the red fused wire with the ring terminal to the positive (+) battery post. Connect the black wire ring terminal to the negative (-) battery post or other suitable vehicle grounding point.

Step 4

Mount the provided relay to the vehicle and secure all wires with zip ties away from moving parts to avoid damage. Test the lights to ensure proper function.

Notes and Maintenance

Before you begin installation, read all instructions thoroughly.

Periodic inspection of all wires and connections should be performed to ensure there is no visible damage or loose connections.

WARNING: Improper electrical installation may damage electronic components resulting in personal injury, property or equipment damage. Damaged caused by incorrect installation is not covered by warranty. Installation should only be performed by qualified personnel with asolid understanding of electrical systems.

Basic Dimensions

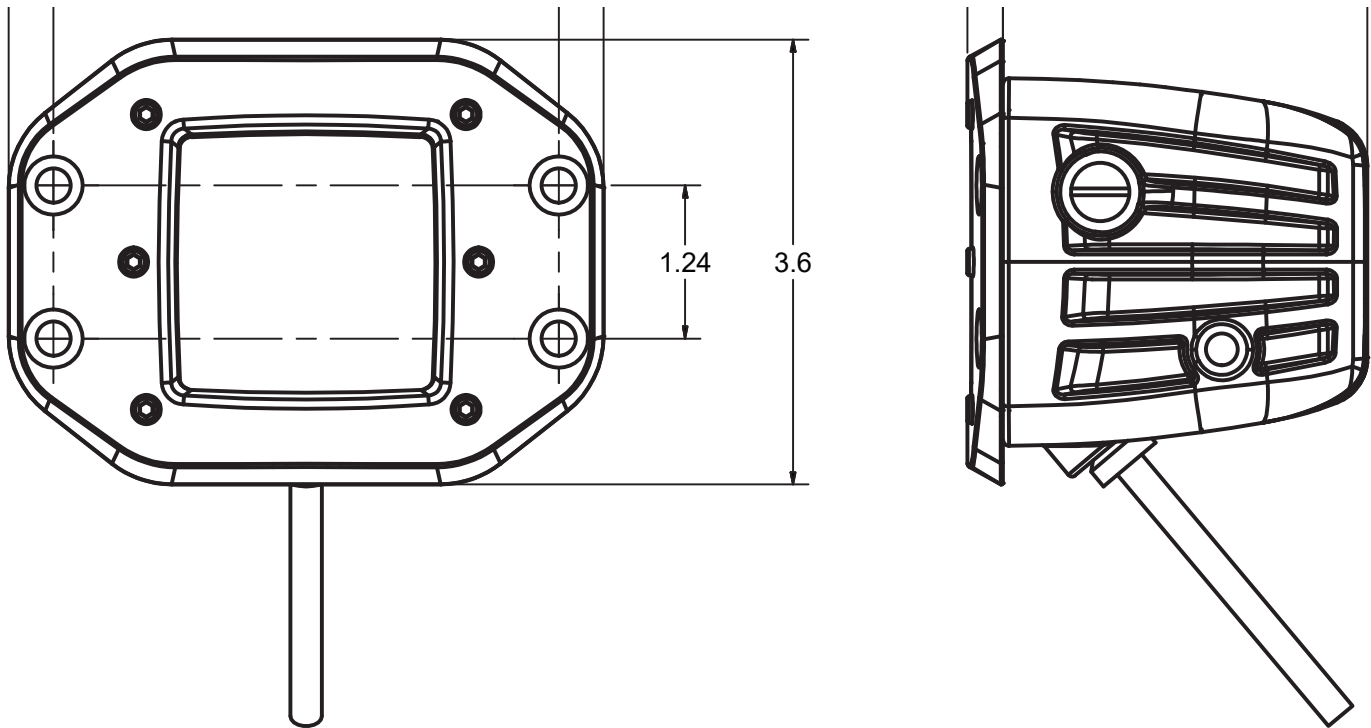

Mounting Dimension - Not to scale

