

Air Lift 1000™

Kit 81560



INSTALLATION GUIDE

For maximum effectiveness and safety, please read these instructions completely before proceeding with installation.

Failure to read these instructions can result in an incorrect installation.



TABLE OF CONTENTS

Introduction	2
Important Safety Notice	2
Notation Explanation	2
Installing the Air Lift 1000 System	3
Hardware List	3
Tools List	3
Getting Started	3
Installing the Air Spring	4
Installing the Protectors	4
Installing the Air Lines	5
Maintenance and Use Guidelines	6
Min/Max Air Pressure	6
Installation Checklist	6
Limited Warranty and Return Policy	8

Introduction

The purpose of this publication is to assist with the installation and of the Air Lift 1000 air spring kit.

It is important to read and understand the entire installation guide before beginning installation or performing any maintenance, service or repair. The information here includes a hardware list, tools list, step-by-step installation information, installation checklist, maintenance tips, and safety information.

Air Lift Company reserves the right to make changes and improvements to its products and publications at any time. Contact Air Lift Company at (800) 248-0892 or go online at www.airliftcompany.com for the latest version of this manual.

IMPORTANT SAFETY NOTICE

The installation of this kit does not alter the Gross Vehicle Weight Rating (GVWR) or payload of the vehicle. Check your vehicle's owner's manual and do not exceed the maximum load listed for your vehicle.

Gross Vehicle Weight Rating: The maximum allowable weight of the fully loaded vehicle (including passengers and cargo). This number — along with other weight limits, as well as tire, rim size and inflation pressure data — is shown on the vehicle's Safety Compliance Certification Label.

Payload: The combined, maximum allowable weight of cargo and passengers that the truck is designed to carry. Payload is GVWR minus the Base Curb Weight.

NOTATION EXPLANATION

Hazard notations appear in various locations in this publication. Information which is highlighted by one of these notations must be observed to help minimize risk of personal injury or possible improper installation which may render the vehicle unsafe. Notes are used to help emphasize areas of procedural importance and provide helpful suggestions. The following definitions explain the use of these notations as they appear throughout this guide.

 **DANGER**

INDICATES IMMEDIATE HAZARDS WHICH WILL RESULT IN SEVERE PERSONAL INJURY OR DEATH.

 **WARNING**

INDICATES HAZARDS OR UNSAFE PRACTICES WHICH COULD RESULT IN SEVERE PERSONAL INJURY OR DEATH.

 **CAUTION**

INDICATES HAZARDS OR UNSAFE PRACTICES WHICH COULD RESULT IN DAMAGE TO THE MACHINE OR MINOR PERSONAL INJURY.

NOTE

Indicates a procedure, practice or hint which is important to highlight.

HARDWARE LIST

Item	Part #	Description.....Qty
A	48171	Air spring..... 2
B	09333	Upper & lower protectors..... 4
C	10551	Air line clip..... 2
D	10466	Zip tie..... 4
E	21230	Valve cap..... 2
F	20081	Air line assembly..... 2
G	21233	5/16" Hex nut..... 4
H	21234	Rubber washer..... 2
I	18411	Star washer..... 2
J	18501	M8 Flat washer..... 2
K	18422	3/8" Lock nut..... 2

TOOLS LIST

Description.....	Qty
Hoist or floor jacks	2
Safety stands.....	1
Safety glasses	1
Grease	1
1" - 1 1/2" hole saw cutter	1
Locking pliers	1
9/16" ratchet.....	1
Drill	1
Air compressor or compressed air source	1
Spray bottle with dish soap/water solution.....	1
String.....	1



Missing or damaged parts? Call Air Lift customer service at (800) 248-0892 for a replacement part.

Installing the Air Lift 1000 System



COMPRESSED AIR CAN CAUSE INJURY AND DAMAGE TO THE VEHICLE AND COMPONENTS IF IT IS NOT HANDLED PROPERLY. FOR YOUR SAFETY, DO NOT TRY TO INFLATE THE AIR SPRINGS UNTIL THEY HAVE BEEN PROPERLY SECURED TO THE VEHICLE.

GETTING STARTED

1. Set the brake, block the wheels and jack up front of vehicle. Place safety stands under the frame and allow the suspension to be fully extended.

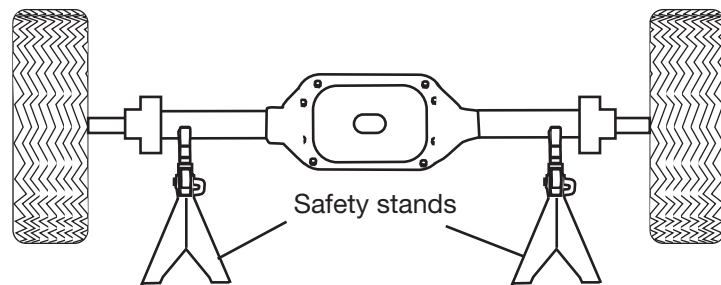

If replacing black O.E.M. air springs:

2. Deflate air springs by removing the valve cores using a tooled valve cap or a knife to puncture the air spring.
3. Use 1" - 1 1/2" hole saw cutter (drill bit removed), to cut the valve out of the air spring.
4. Use locking pliers and clamp onto the bottom of the air spring and pull the air spring through the hole, twisting as you pull. Spraying the air spring with a soapy water solution may ease removal.
5. Remove the upper protector through the side of the coil.

INSTALLING THE AIR SPRING

1. Remove black valve cap (E) and roll the air spring (A) up toward the stem end to exhaust as much air as possible (Fig. 2).
2. Install black valve cap to maintain this compressed shape.

NOTE

You may notice some discoloration of the cylinder in the “rolled up” condition. This is normal and does not harm or indicate damage to the cylinder in any way. The “discoloration” actually reflects the natural color of the polyurethane material before we add the red pigment

3. Unroll the air spring and fold it lengthwise (Fig. 2). Use string to hold it in this position, if necessary.

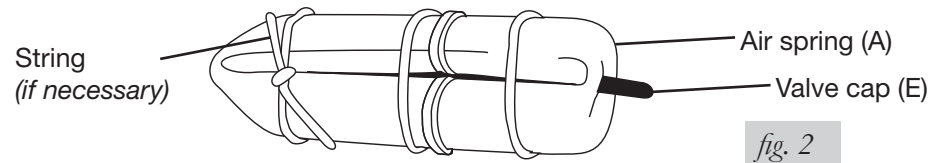

4. Check the hole in the lower control arm and deburr/smooth sharp edges, if necessary, to prevent damage to the air spring. Insert the air spring through the hole in the lower control arm (valve stem facing down). Spraying the air spring with a soapy water solution may ease installation.
5. Push the air spring up with a twisting action into the coil, leaving about 2” (51mm) extended out of the bottom of the coil (Fig. 3).

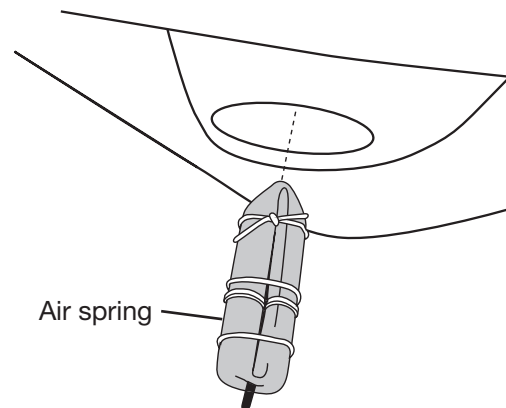

INSTALLING THE PROTECTORS

1. Before pushing the air spring completely into the coil, insert and position the upper protector (B) on the stud on the top of the air spring (Fig. 4). A light coating of grease on the top side will help hold it in place.

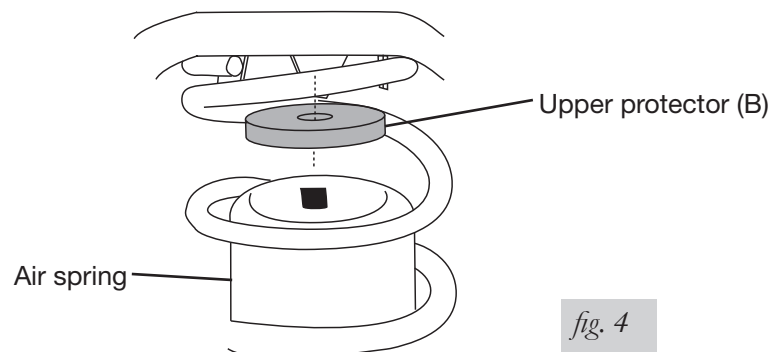

2. Push the air spring into coil spring. If previously used, remove the string from the air spring.
3. Once the air spring is in place, insert and position the lower protector (B) by pushing the air spring up and sliding the protector under the air spring (Fig. 5).

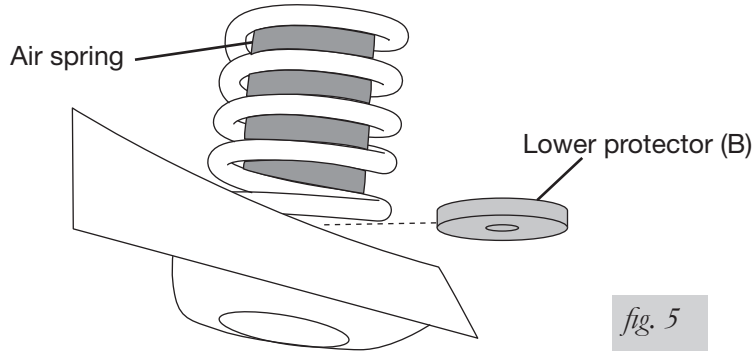

INSTALLING THE AIR LINES

1. Choose the locations for the Schrader valves and drill a 5/16" (8mm) hole, if necessary (Fig. 6).

- A. Inside fuel tank filler door C. License plate or rear bumper area
 B. Inside rear wheel wells

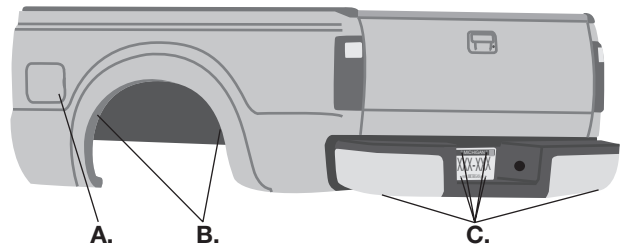

CAUTION

KEEP AT LEAST 6" (152MM) OF CLEARANCE BETWEEN ALL AIR LINES AND THE EXHAUST SYSTEM. AVOID SHARP BENDS AND EDGES.

2. Lower the air spring, guiding the valve stem through the hole in the lower protector (Fig. 7).
3. Attach the elbow fitting on the air line (F) to the valve stem. Orient the elbow and air line to line up with the existing sway bar attaching bolts. Finger tighten the elbow nut.
4. Place the supplied clip (C) around the air line (Fig. 7).
5. Attach the clip to the existing sway bar attaching bolt with the provided 3/8" lock nut (K).
6. Tighten the 3/8" lock nut (K) using a 9/16" ratchet.
7. Route the air line up the lower control arm toward the center of the vehicle.

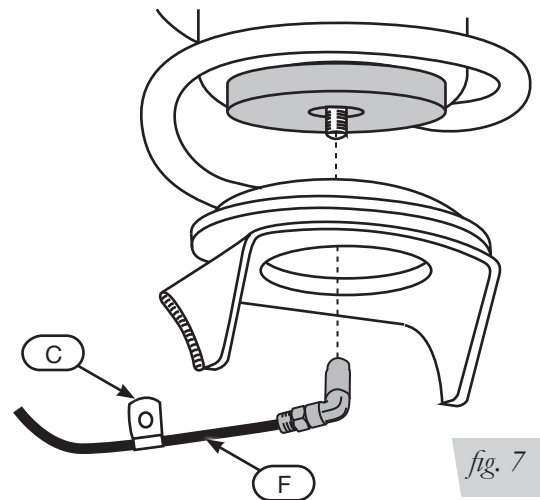

CAUTION

BE SURE THAT THE AIR LINE GOES OVER THE TOP OF THE CONTROL ARM AND ALONG THE SUPPORT FRAME.

8. Route the air line through the frame to a selected valve stem mounting location. Secure the air line with zip ties (D), away from brake lines and battery.

CAUTION

DO NOT PINCH OR KINK THE AIR LINE. THE MINIMUM BEND RADIUS FOR THE AIR LINE IS 1" (25MM). LEAVE AT LEAST 2" (50MM) OF SLACK IN THE AIR LINE TO ALLOW FOR ANY MOVEMENT THAT MIGHT PULL ON THE AIR LINE.

9. Install the Schrader valve in the chosen location (Fig. 8).

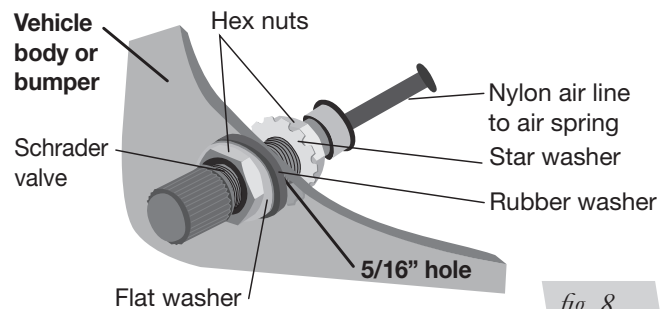

Maintenance and Use Guidelines

1. Check air pressure weekly.
2. Always maintain normal ride height. Never inflate beyond 90 PSI (6.2BAR) for motorhomes and commercial chassis, 50 PSI (3.5BAR) for trucks and passenger vans.
3. If the system develops an air leak, use a soapy water solution to check all air line connections and the inflation valve core before deflating and removing the air spring.

Minimum Air Pressure	Maximum Air Pressure
Motorhomes and Commercial Chassis	
40 PSI (2.8BAR)	90 PSI (6.2BAR)
Trucks and Passenger Vans	
10 PSI (0.7BAR)	50 PSI (3.5BAR)
FAILURE TO MAINTAIN CORRECT MINIMUM PRESSURE (OR PRESSURE PROPORTIONAL TO LOAD), BOTTOMING OUT, OVER-EXTENSION OR RUBBING AGAINST ANOTHER COMPONENT WILL VOID THE WARRANTY.	

CAUTION

FOR SAFETY AND TO PREVENT POSSIBLE DAMAGE TO THE VEHICLE, DO NOT EXCEED MAXIMUM GROSS VEHICLE WEIGHT RATING (GVWR) OR PAYLOAD RATING, AS INDICATED BY THE VEHICLE MANUFACTURER.

CAUTION

ALTHOUGH THE AIR SPRINGS ARE RATED AT A MAXIMUM INFLATION PRESSURE OF 90 PSI (6.2BAR) FOR MOTORHOMES AND COMMERCIAL CHASSIS, 50 PSI (3.5BAR) FOR TRUCKS AND PASSENGER VANS, THE AIR PRESSURE ACTUALLY NEEDED IS DEPENDENT ON LOAD AND GROSS VEHICLE WEIGHT RATING.

INSTALLATION CHECKLIST

- Clearance test** — Inflate the air springs to 40-60 PSI (2.8-4.1BAR) and make sure there is at least 1/2" (13mm) clearance from anything that might rub against each air spring. Be sure to check the tire, brakes, frame, shock absorbers and brake cables.
- Leak test before road test** — Inflate the air springs to 40-60 PSI (2.8-4.1BAR) and check all connections for leaks. All leaks must be eliminated before the vehicle is road tested.
- Heat test** — Be sure there is sufficient clearance from heat sources, at least 6" (152mm) for air springs and air lines. If a heat shield was included in the kit, install it. If there is no heat shield, but one is required, call Air Lift customer service at **(800) 248-0892**.
- Fastener test** — Recheck all bolts for proper torque.
- Road test** — The vehicle should be road tested after the preceding tests. Inflate the springs to recommended driving pressures. Drive the vehicle 10 miles (16km) and recheck for clearance, loose fasteners and air leaks.
- Operating instructions** — If professionally installed, the installer should review the operating instructions with the owner. Be sure to provide the owner with all of the paperwork that came with the kit.

Limited Warranty and Return Policy

Air Lift Company provides a limited lifetime warranty to the original purchaser of its load support products, that the products will be free from defects in workmanship and materials when used on cars and trucks as specified by Air Lift Company and under normal operating conditions, subject to the requirements and exclusions set forth in the full Limited Warranty and Return Policy that is available at www.airliftcompany.com/warranty.

For additional warranty information contact Air Lift Company customer service.

Air Lift Company reserves the right to make changes and improvements to its products and publications at any time. For the latest version of this manual, contact Air Lift Company at **(800) 248-0892** or visit www.airliftcompany.com.

Need Help?

Contact our customer service department by calling (800) 248-0892. For calls from outside the USA or Canada, our local number is (517) 322-2144.

Register your warranty online at
www.airliftcompany.com/warrantyreg.htm



Thank you for purchasing Air Lift products — the professional installer's choice!

Air Lift Company • 2727 Snow Road • Lansing, MI 48917 or PO Box 80167 • Lansing, MI 48908-0167
Toll Free (800) 248-0892 • Local (517) 322-2144 • Fax (517) 322-0240 • www.airliftcompany.com

Printed in the USA
MB-0519

California: ⚠️ WARNING: Cancer and Reproductive Harm - www.P65Warnings.ca.gov

