

RideControl™

Kit 59561



INSTALLATION GUIDE

For maximum effectiveness and safety, please read these instructions completely before proceeding with installation.

Failure to read these instructions can result in an incorrect installation.



TABLE OF CONTENTS



| | |
|--|----------|
| Introduction | 2 |
| Notation Explanation | 2 |
| Installation Diagram | 3 |
| Hardware List | 3 |
| Tools List | 3 |
| Installing the RideControl System | 4 |
| Attaching the Upper Bracket | 4 |
| Attaching the Lower Bracket | 4 |
| Mounting the Assembly | 5 |
| Installing the Air Lines | 6 |
| Installation Checklist | 7 |
| Maintenance and Use Guidelines | 7 |
| Minimum and Maximum Recommended Air Pressure | 7 |
| Limited Warranty and Return Policy | 8 |



Introduction

The purpose of this publication is to assist with the installation and maintenance of the RideControl air spring kit.

The air springs are manufactured like a tire with layers of rubber and cords that control growth. The bags do not require a coil spring for control. RideControl kits utilize a sleeve-style air bag that provides up to 2,000 pounds (907kg) of load-leveling support. Each sleeve is rated at a maximum of 100 PSI (7BAR).

It is important to read and understand the entire installation guide before beginning installation or performing any maintenance, service or repair.

NOTATION EXPLANATION

Hazard notations appear in various locations in this publication. Information which is highlighted by one of these notations must be observed to help minimize risk of personal injury or possible improper installation which may render the vehicle unsafe. Notes are used to help emphasize areas of procedural importance and provide helpful suggestions. The following definitions explain the use of these notations as they appear throughout this guide.

**DANGER**

INDICATES IMMEDIATE HAZARDS WHICH WILL RESULT IN SEVERE PERSONAL INJURY OR DEATH.

**WARNING**

INDICATES HAZARDS OR UNSAFE PRACTICES WHICH COULD RESULT IN SEVERE PERSONAL INJURY OR DEATH.

**CAUTION**

INDICATES HAZARDS OR UNSAFE PRACTICES WHICH COULD RESULT IN DAMAGE TO THE MACHINE OR MINOR PERSONAL INJURY.

Installation Diagram

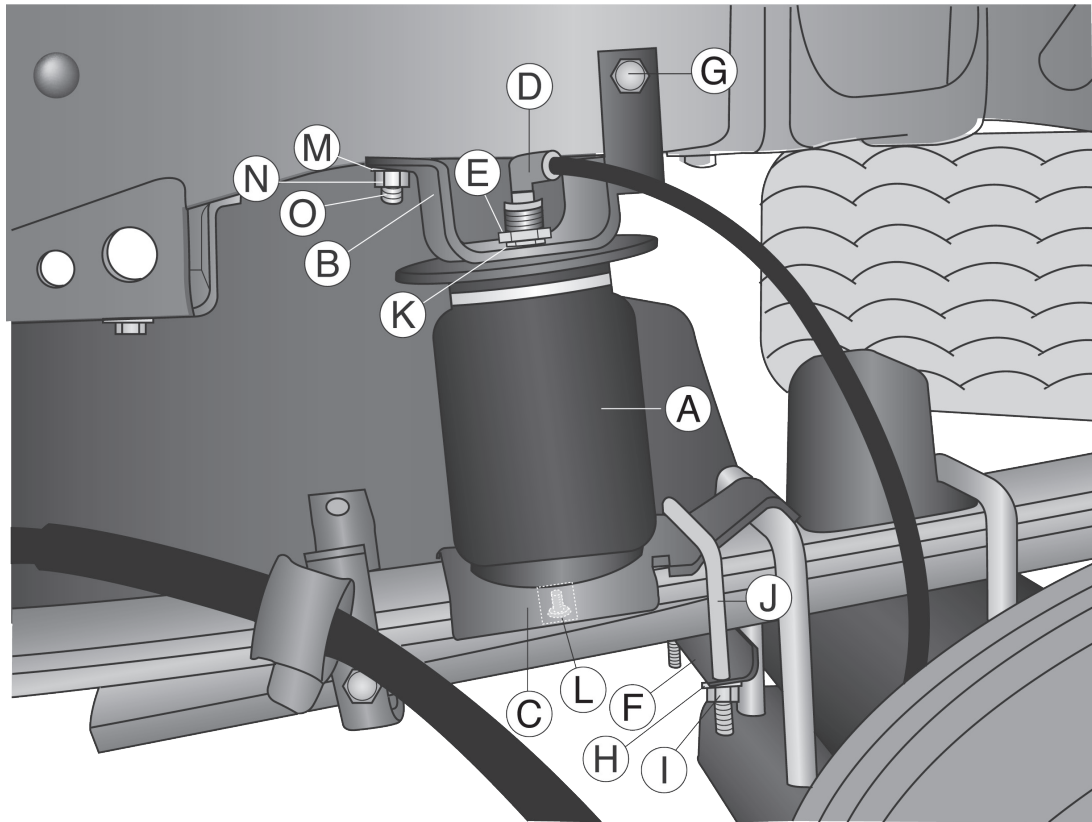

fig. 1

HARDWARE LIST

| Item | Description.....Qty | Item | Description.....Qty |
|------|---------------------------|------|----------------------------------|
| A | Air sleeve.....2 | K | Serrated washer.....2 |
| B | Upper bracket.....2 | L | 1/2"-13 x 3/4" Tapper bolt.....2 |
| C | Lower bracket.....2 | M | M8 Flat washer.....2 |
| D | Air fitting.....2 | N | M8 Nylon lock nut.....2 |
| E | 3/4"-16 Jam nut.....2 | O | M8 x 1.25 x 25 Flange bolt.....2 |
| F | Clamp bar.....2 | CC | Valve cap.....2 |
| G | 3/8"-16 x 1" Bolt.....2 | DD | 5/16" Flat washer.....2 |
| H | 3/8" Flat washer.....8 | EE | Rubber washer.....2 |
| I | 3/8" Nylon lock nut.....6 | FF | Star washer.....2 |
| J | U-bolt.....2 | GG | 5/16" Hex nut.....4 |

STOP! Missing or damaged parts? Call Air Lift customer service at (800) 248-0892 for a replacement part.

TOOLS LIST

| Description.....Qty | Description.....Qty |
|------------------------------------|---|
| Hoist or floor jacks.....1 | Ratchet with 9/16" and metric deep well sockets 1 |
| Safety stands.....2 | 5/16" drill bits (very sharp).....2 |
| Safety glasses.....1 | Heavy duty drill.....1 |
| Torque wrench.....1 | Hose cutter, razor blade, or sharp knife.....1 |
| 9/16" open-end or box wrench.....1 | Air compressor or compressed air source.....1 |
| Crescent wrench.....1 | Spray bottle with dish soap/water solution.....1 |

Installing the RideControl System

ATTACHING THE UPPER BRACKET

1. Attach the upper bracket to the sleeve using the serrated washer and nylon nut (fig. 1). Leave loose at this time.
2. Install the elbow fitting into air port of the air sleeve. The fitting is precoated with thread sealant. Tighten finger tight plus 1 1/2 turns. Use an open end wrench being careful to tighten on the metal hex nut only. Do not overtighten.
3. Repeat step 1 for the opposite side of the vehicle.

ATTACHING THE LOWER BRACKET

1. Attach the lower bracket using the supplied taper head screw. Be sure to use the correct holes designated for the driver-side and passenger-side assemblies (figs. 2 and 3). Tighten securely.

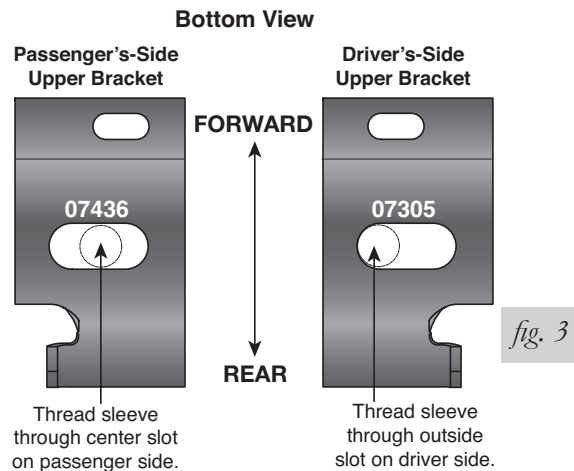
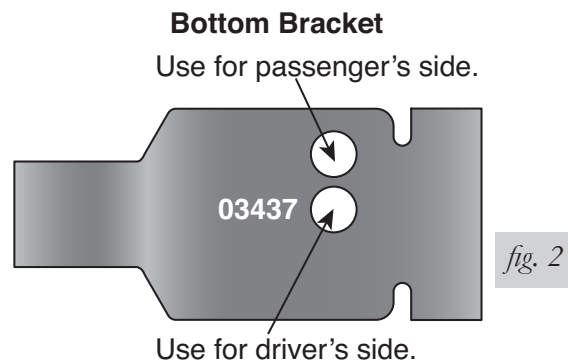

2. Repeat for the opposite side of the vehicle.

MOUNTING THE ASSEMBLY

1. Set the driver-side assembly on the leaf spring forward of the axle. Attach the upper bracket to the frame using the existing holes in the frame (fig. 4). On the side of the frame loosely install with the 3/8" bolt (G) (outside frame) through bracket and frame, cap with a flat washer (H) and nylon lock nut (I). On the bottom frame flange attach the bracket with the M8 bolt (O) through the frame, then bracket (fig. 1) cap with flat washer (M) and nylon lock nut (N). Tighten the side frame bolt first to 25 lb.-ft. (34Nm), then tighten the bottom frame/bracket flange bolt to 10 lb.-ft. (14Nm). Repeat for the other side.

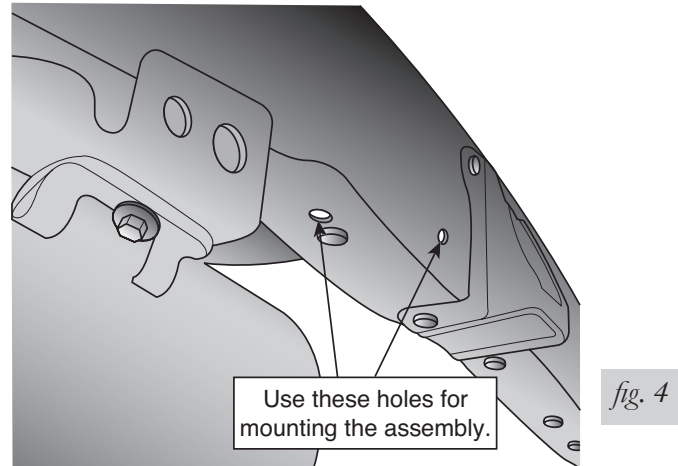

2. Set the curved "finger" of the lower bracket over the axle u-bolt. Attach the lower bracket to the leaf spring by installing the supplied U-bolt over the bracket and leaf spring.
3. Slide a clamp bar over the u-bolt installed in step 2 and attach using two flat washers and two nylon lock nuts (fig. 1). Torque to 16 lb.-ft. (22Nm).

Installing the Air Lines

Choose the locations for the Schrader valves and drill a 5/16" (8mm) hole, if necessary (Fig. 5).

1. Cut the air line in half. Make clean, square cuts with a razor blade or hose cutter (Fig. 6). Do not use scissors or wire cutters.

- A. Inside fuel tank filler door
 B. Inside rear wheel wells
 C. License plate or rear bumper area

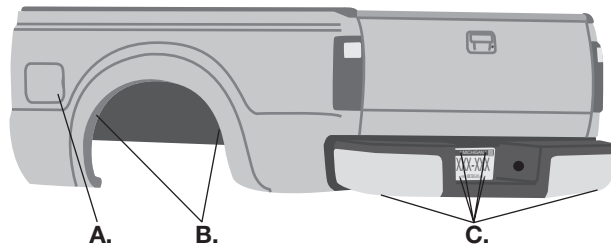
fig. 5

CAUTION

KEEP AT LEAST 6" (152MM) OF CLEARANCE BETWEEN ALL AIR LINES AND THE EXHAUST SYSTEM. AVOID SHARP BENDS AND EDGES.

2. Use zip ties to secure the air line to fixed points along the chassis. Do not pinch or kink the air line. Leave at least 2" of slack in the air line to allow for any movement that might pull on the air line. The minimum bend radius for the air line is 1" (25mm).

Good cut

Bad cut

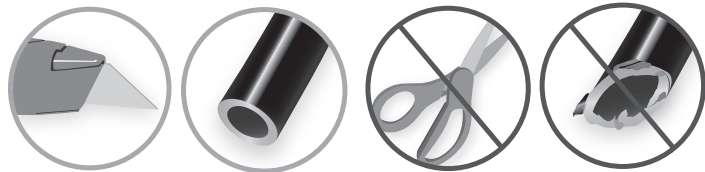
fig. 6

3. Install the Schrader valve in the chosen location (Fig. 7).

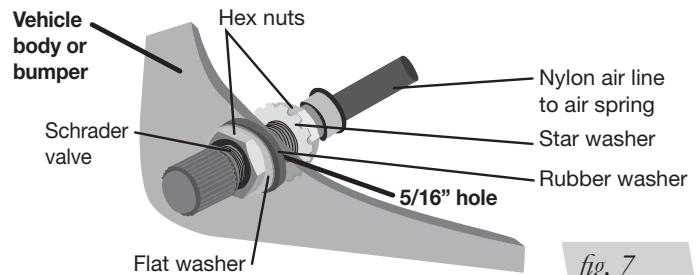
fig. 7

INSTALLATION CHECKLIST

- Clearance test** — Inflate the air springs to 40-60 PSI (2.8-4.1BAR) and make sure there is at least 1/2" (13mm) clearance from anything that might rub against each sleeve. Be sure to check the tire, brakes, frame, shock absorbers and brake cables.
- Leak test before road test** — Inflate the air springs to 40-60 PSI (2.8-4.1BAR) and check all connections for leaks. All leaks must be eliminated before the vehicle is road tested.
- Heat test** — Be sure there is sufficient clearance from heat sources, at least 6" (152mm) for air springs and air lines. If a heat shield was included in the kit, install it. If there is no heat shield, but one is required, call Air Lift customer service at **(800) 248-0892**.
- Fastener test** — Recheck all bolts for proper torque.
- Road test** — The vehicle should be road tested after the preceding tests. Inflate the springs to recommended driving pressures. Drive the vehicle 10 miles (16km) and recheck for clearance, loose fasteners and air leaks.
- Operating instructions** — If professionally installed, the installer should review the operating instructions with the owner. Be sure to provide the owner with all of the paperwork that came with the kit.

Maintenance and Use Guidelines

1. Check air pressure weekly.
2. Always maintain normal ride height. Never inflate beyond 100 PSI (7BAR).
3. If the system develops an air leak, use a soapy water solution to check all air line connections and the inflation valve core before deflating and removing the air spring.

| Minimum Recommended Pressure | Maximum Air Pressure |
|------------------------------|-----------------------|
| 5 PSI (.34BAR) | 100 PSI (7BAR) |



CAUTION

FOR SAFETY AND TO PREVENT POSSIBLE DAMAGE TO THE VEHICLE, DO NOT EXCEED MAXIMUM GROSS VEHICLE WEIGHT RATING (GVWR) OR PAYLOAD RATING, AS INDICATED BY THE VEHICLE MANUFACTURER.



CAUTION

ALTHOUGH THE AIR SPRINGS ARE RATED AT A MAXIMUM INFLATION PRESSURE OF 100 PSI (7BAR), THE AIR PRESSURE ACTUALLY NEEDED IS DEPENDENT ON LOAD AND GROSS VEHICLE WEIGHT RATING.

Limited Warranty and Return Policy

Air Lift Company provides a limited lifetime warranty to the original purchaser of its load support products, that the products will be free from defects in workmanship and materials when used on cars and trucks as specified by Air Lift Company and under normal operating conditions, subject to the requirements and exclusions set forth in the full Limited Warranty and Return Policy that is available at www.airliftcompany.com/warranty.

For additional warranty information contact Air Lift Company customer service.

Need Help?

Contact our customer service department by calling (800) 248-0892. For calls from outside the USA or Canada, our local number is (517) 322-2144.

**Register your warranty online at
www.airliftcompany.com/warranty**



Thank you for purchasing Air Lift products — the professional installer's choice!

Air Lift Company • 2727 Snow Road • Lansing, MI 48917 or PO Box 80167 • Lansing, MI 48908-0167
Toll Free (800) 248-0892 • Local (517) 322-2144 • Fax (517) 322-0240 • www.airliftcompany.com

Printed in the USA
JJC-0121